

APPROVAL SHEET

MULTILAYER CERAMIC CAPACITORS

Safety Certified X1/Y2 Series

1808 to 2220 Sizes

NP0 & X7R Dielectrics

RoHS Compliance

*Contents in this sheet are subject to change without prior notice.

1. INTRODUCTION

WTC's SAFETY CERTIFIED CAPACITORS are designed for surge or lightning immunity in modem facsimile and other equipments. The capacitors of series S2 are class X1/Y2 compliant respectively.

The green type capacitors in S2 and S3 series are manufactured by using environmentally friendly materials without lead or cadmium.

The terminations are composed of plated nickel and pure tin to feature the superior leaching resistance during soldering.

2. FEATURES

- a. High reliability and stability.
- b. Small size and high capacitance
- c. RoHS compliant
- d. Safety standard approval by
EN 60384-14:2005, IEC 60384-14:2005,
EN 60384-14:2005,
UL 60950:2000, UL 60384-14
- e. Certificate number:
TUV: R500021351, R50118359, R50195920,
UL: E250427, E182369
- f. HALOGEN compliant

3. APPLICATIONS

- a. Modem.
- b. Facsimile.
- c. Telephone.
- d. Other electronic equipment for lightning or surge protection and isolation.



4. HOW TO ORDER

S2	42	N	100	J	302	L	I
Series	Size	Dielectric	Capacitance	Tolerance	Rated voltage	Termination	Packaging
S2=X1/Y2	42=1808 (4520) 43=1812 (4532) 52=2211 (5728) 55=2220 (5750)	N=NP0 B=X7R	Two significant digits followed by no. of zeros. And R is in place of decimal point. eg.: 0R5=0.5pF 1R0=1.0pF 100=10x10 ⁰ =10pF	B= ±0.1pF C= ±0.25pF D= ±0.5pF F= ±1.0% G= ±2.0% J= ±5.0% K= ±10% M= ±20%	Two significant digits followed by no. of zeros. And R is in place of decimal point. 202: 2000VDC 302: 3000VDC 502: 5000 Impulse Voltage 602: 6000 Impulse Voltage	C=Cu/Ni/Sn L=Ag/Ni/Sn	T=7" reeled

* Partial items are with Cu/Ni/Sn terminations, please ref to product range for detail.

5. EXTERNAL DIMENSIONS & STRUCTURE

Size Inch (mm)	L (mm)	W (mm)	Tmax (mm)	M _B min (mm)
1808 (4520)	4.50±0.50	2.00±0.28	2.20	0.26
1812 (4532)	4.50±0.50	3.20±0.40	2.80	0.26
2211 (5728)	5.70±0.40	2.80±0.30	2.80	0.30
2220 (5750)	5.70±0.40	5.00±0.40	3.10	0.30

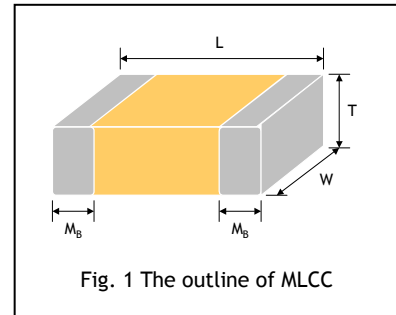

Fig. 1 The outline of MLCC

6. GENERAL ELECTRICAL DATA

Dielectric	NP0	X7R
Size	1808, 1812, 2211	1808, 1812, 2211, 2220
Capacitance	4pF to 680pF	100pF to 4700pF
Capacitance tolerance	J (±5%), K (±10%)	
Rated voltage (WVAC)	250Vac	
Q/ DF(Tan δ)	Cap<30pF: Q≥400+20C	DF≤2.5%
Insulation resistance at U _r	≥10GΩ	
Peak impulse voltage	5000V ~ 6000V	
Operating temperature	-55 to +125°C	
Capacitance characteristic	±60ppm	±15%
Termination	Ni/Sn (lead-free termination)	
Certified number	TUV: R500021351, R50118359, R50195920, UL: E250427, E182369	
Test standard	EN 60384-14:2005, IEC 60384-14:2005, EN 60384-14:2005, UL 60950:2000, UL 60384-14	

* NP0 : Apply 1.0±0.2Vrms, 1.0MHz±10%, at 25°C ambient temperature

X7R: Apply 1.0±0.2Vrms, 1.0kHz±10%, at 25°C ambient temperature.

7. PACKAGE DIMENSION AND QUANTITY

Size	Thickness (mm)/Symbol		Plastic tape	
			7" reel	13" reel
1808 (4520)	1.40±0.15	F	2k	-
	1.60±0.20	G	2k	8k
	2.00±0.20	K	1k	6k
1812 (4532)	1.60±0.20	G	1k	-
	2.00±0.20	K	1k	-
	2.50±0.30	M	0.5k	3k
2211 (5728)	1.60±0.20	G	1k	-
	2.00±0.20	K	1k	-
	2.50±0.30	M	0.5k	-
2220 (5750)	2.00±0.20	K	1k	-
	2.50±0.30	M	0.5k	-

Unit: pieces

8.CAPACITANCE RANGE

DIELECTRIC		NP0			
SIZE		1808	1812	2211	
RATED VOLTAGE (VDC)		3000	3000	3000	
PEAK IMPULSE VOLTAGE		5000	5000	5000	6000
Capacitance	4pF (4R0)	F		K	K*
	5pF (5R0)	F		K	K*
	10pF (100)	F	D	K	K*
	12pF (120)	F	D	K	K*
	15pF (150)	F	D	K	K*
	18pF (180)	F	D	K	K*
	22pF (220)	F	D	K	K*
	27pF (270)	F	D	K	K*
	33pF (330)	F	D	K	K*
	39pF (390)	G	D	K	K*
	47pF (470)	G	D	K	K*
	56pF (560)	G	D	K	K*
	68pF (680)	G	D	K	M*
	82pF (820)	G	D	K	M*
	100pF (101)	K	D	K	U*
	120pF (121)	K	D	M	
	150pF (151)	K	D	M	
	180pF (181)		D	M	
	220pF (221)		K	M	
	270pF (271)		K	M	
330pF (331)		K	M		
390pF (391)		K	M		
470pF (471)		K	M		
560pF (561)			M		
680pF (681)			M		

1. The letter in cell is expressed the symbol of product thickness.
2. For more information about products with special capacitance or other data, please contact WTC local representative.
3. The letter in cell with "*" mark is expressed product with Cu/Ni/Sn terminations.

DIELECTRIC		X7R			
SIZE		1808	1812	2211	2220
RATED VOLTAGE (VDC)		3000			
PEAK IMPULSE VOLTAGE		5000			
Capacitance	56pF (560)				
	68pF (680)				
	82pF (820)				
	100pF (101)	G			
	120pF (121)	G			
	150pF (151)	G	G	G	
	180pF (181)	G	G	G	K
	220pF (221)	G	G	G	K
	270pF (271)	K	G	G	K
	330pF (331)	K	G	G	K
	390pF (391)	K	G	G	K
	470pF (471)	K	G	K	K
	560pF (561)	K	G	K	K
	680pF (681)	K	K	K	K
	820pF (821)	K	K	K	K
	1,000pF (102)	K	M	M	K
	1,200pF (122)			M	M
	1,500pF (152)			M	M
	1,800pF (182)			M	M
	2,200pF (222)			M	M
2,700pF (272)				M	
3,300pF (332)				M	
4,700pF (472)				M	

1. The letter in cell is expressed the symbol of product thickness.
2. For more information about products with special capacitance or other data, please contact WTC local representative.

EMBOSSED TAPE DIMENSIONS

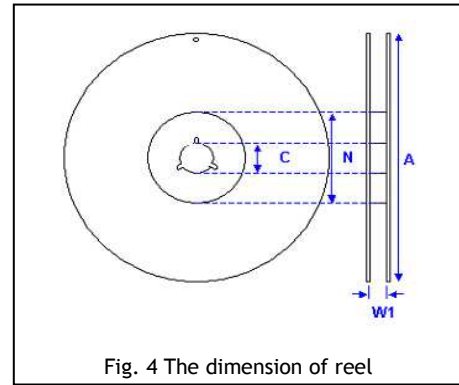
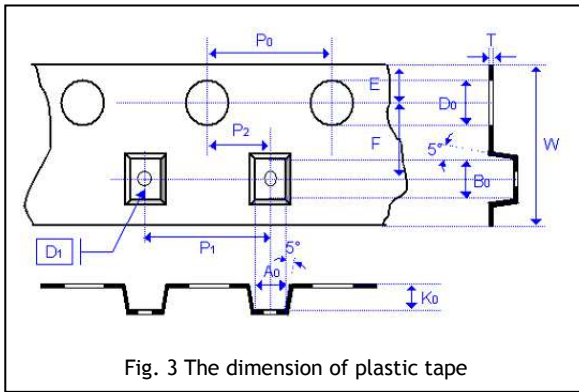

Size	1808		1812		2211		2220	
Chip Thickness	1.25±0.10		1.25±0.10		1.60±0.20		2.00±0.20	
	1.40±0.15	2.00±0.20	1.60±0.20	2.50±0.30	2.00±0.20	2.50±0.30	2.00±0.20	2.50±0.30
	1.60±0.20		2.00±0.20					
A ₀	<2.50	<2.50	<3.90	<3.90	<3.30	<3.30	<3.30	<3.30
B ₀	<5.30	<5.30	<5.30	<5.30	<6.50	<6.50	<6.50	<6.50
T	0.25±0.05	0.25±0.05	0.25±0.05	0.25±0.05	0.30±0.10	0.30±0.10	0.30±0.10	0.30±0.10
K ₀	<2.50	<2.50	<2.50	<3.00	<2.50	<3.10	<2.50	<3.10
W	12.0±0.20	12.0±0.20	12.0±0.20	12.0±0.20	12.0±0.20	12.0±0.20	12.0±0.20	12.0±0.20
P ₀	4.00±0.10	4.00±0.10	4.00±0.10	4.00±0.10	4.00±0.10	4.00±0.10	4.00±0.10	4.00±0.10
10xP ₀	40.0±0.20	40.0±0.20	40.0±0.20	40.0±0.20	40.0±0.20	40.0±0.20	40.0±0.20	40.0±0.20
P ₁	4.00±0.10	4.00±0.10	8.00±0.10	8.00±0.10	8.00±0.10	8.00±0.10	8.00±0.10	8.00±0.10
P ₂	2.00±0.05	2.00±0.05	2.00±0.05	2.00±0.05	2.00±0.05	2.00±0.05	2.00±0.05	2.00±0.05
D ₀	1.50+0.10/-0	1.50+0.10/-0	1.50±0.10/-0	1.50+0.10/-0	1.50+0.10/-0	1.50+0.10/-0	1.50+0.10/-0	1.50+0.10/-0
D ₁	1.50±0.10	1.50±0.10	1.50±0.10	1.50+/-0.10	1.50±0.10	1.50±0.10	1.50±0.10	1.50±0.10
E	1.75±0.10	1.75±0.10	1.75±0.10	1.75+/-0.1	1.75±0.1	1.75±0.10	1.75±0.1	1.75±0.10
F	5.50±0.05	5.50±0.05	5.50±0.05	5.50+/-0.05	5.50±0.05	5.50±0.05	5.50±0.05	5.50±0.05

Size	1808, 1812, 2211, 2220
Reel size	7"
C	13.0+0.5/-0.2
W ₁	12.4+2.0/-0
A	178.0±0.10
N	80.0±1.0

9. APPLICATION NOTES

STORAGE

To prevent the damage of solderability of terminations, the following storage conditions are recommended:

Indoors under 5 ~ 40°C and 20% ~ 70% RH.

No harmful gases containing sulfuric acid, ammonia, hydrogen sulfide or chlorine.

Packaging should not be opened until the capacitors are required for use. If opened, the pack should be re-sealed as soon as is practicable. Taped product should be stored out of direct sunlight, which might promote deterioration in tape or adhesion performance. The capacitors should be used within 6 months and checked the solderability before use.

HANDLING

Chip capacitors are dense, hard, brittle, and abrasive materials. They are liable to suffer mechanical damage, in the form of cracks or chips. Chip Capacitors should be handled with care to avoid contamination or damage. To use vacuum or plastic tweezers to pick up or plastic tweezers is recommended for manual placement. Tape and reeled packages are suitable for automatic pick and placement machine.

PREHEAT

In order to minimize the risk of thermal shock during soldering, a carefully controlled preheat is required. The rate of preheat should not exceed 4°C per second and the final preheat temperature should be within 50°C of the soldering temperature for bigger chips such as 1808, 1812, 2211, 2220 etc.

SOLDERING

Use middy activated rosin RA and RMA fluxes do not use activated flux. The amount of solder in each solder joint should be controlled to prevent the damage of chip capacitors caused by the stress between solder, chips, and substrate.

Hand soldering with temperature-controlled iron not exceeding 30 watts and diameter of tip less than 1.2 mm is recommended, tip of iron should not contact the ceramic body directly, and the temperature of iron should be set to not more than 260°C.

For bigger chips such as 1808, 1812, 2211, 2220 etc. wave soldering and hand soldering are not recommended.

Refer IPC/JEDEC J-STD-020D Method recommended soldering profiles :

Reflow not sooner than 15 minutes and not longer than 4 hrs after removal from the temperature/humidity chamber, subject the sample to 3 cycle of the appropriate reflow conditions as defined as blow Table description.

Profile Feature	Pb-Free Assembly
Preheat/Soak	
Temperature Min.(T _{smin})	150°C
Temperature Max.(T _{smax})	200°C
Time(t _s) from (T _{smin} to T _{smax})	60 to 120 seconds
Ramp-up rate(T _L to T _p)	3°C/second max.
Liquidous temperature(T _L)	217°C
Time(t _L) maintained above T _L	60 to 150 seconds
Peak package body temperature(T _p)	For user T _p must not exceed the Classification temp 260°C For suppliers T _p must equal or exceed the Classification temp 260°C
Time(T _p)* within 5°C of the specified classification temperature(T _c)	30* second
Ramp-down rate (T _p to T _L)	6°C/second max.
Time 25°C to peak temperature 260°C	8 minutes max.

Lead-free : Soldering temperature = 235 to 260°C, depending on product.

Maximum temperature = Minimum temperature(235°C)+ΔT+ Tolerance for oven process and measurement(5 ~ 7°C)

Time at peak temperature = 10sec, Dwell above 217°C = 90sec, Ramping rate = 3°C/sec(heating) and 6°C/sec(cooling).

Classification Reflow Profiles

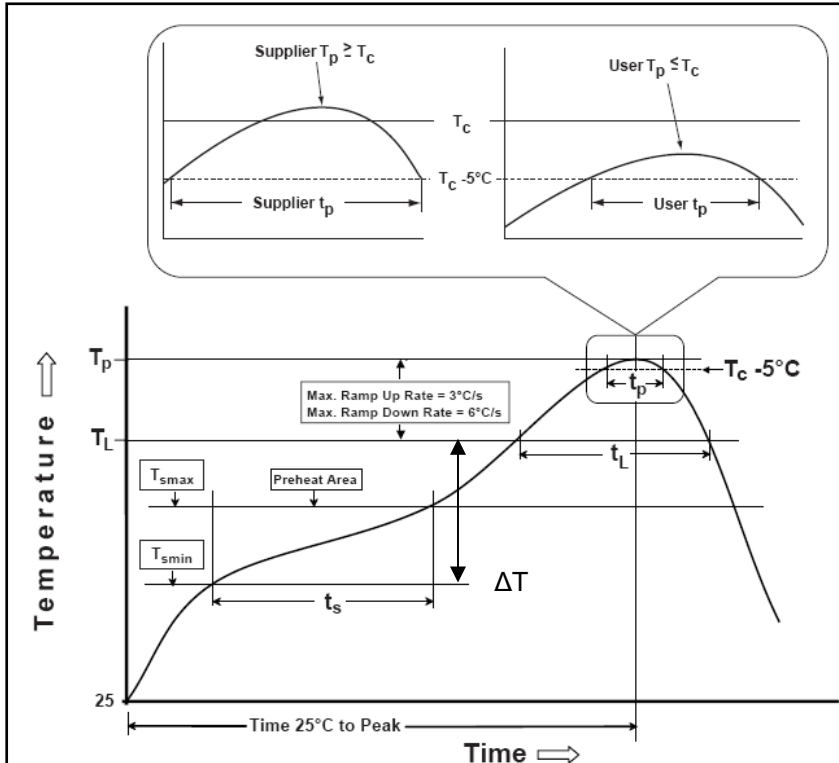

Chip Size	ΔT
1808, 1812, 2211, 2220	50 °C

Soldering	Solder Temp. (T_c)	Soldering Time (t_p)
Reflow	235 – 260 °C	< 15 sec.

Note : For example , T_c is 260°C and time t_p is 15sec.
for user : The peak temperature must not exceed 260°C . The time above 255°C must not exceed 15 seconds.

COOLING

After soldering, cool the chips and the substrate gradually to room temperature. Natural cooling in air is recommended to minimize stress in the solder joint. A cooling rate not exceeding 4°C per second should be used when forced cooling is necessary.

CLEANING

All flux residues must be removed by using suitable electronic-grade vapor-cleaning solvents to eliminate contamination that could cause electrolytic surface corrosion. Good results can be obtained by using ultrasonic cleaning of the solvent. The choice of the proper system is depends upon many factors such as component mix, flux, and solder paste and assembly method. The ability of the cleaning system to remove flux residues and contamination from under the chips is very important.

10.RELIABILITY TEST CONDITIONS AND REQUIREMENTS

No.	Item	Standard Method	Test Condition	Requirements												
1.	Visual examination and Dimensions	IEC 60384-1 4.1		* No remarkable defect. * Dimensions to confirm to individual specification sheet.												
2.	Capacitance	IEC 60384-1 4.2.2	Class I (C0G/NPO): 1.0±0.2Vrms, 1MHz±10% For C _R ≤ 100pF 1KHz±10% For C _R > 100pF	* Capacitance is within specified tolerance * C _R means rated capacitance for conform to the E6 series of preferred values given in IEC 60063.												
3.	D.F. (Dissipation Factor) Tangent of loss angle	IEC 60384-1 4.2.3	Class II (X7R): 1.0±0.2Vrms, 1KHz±10%	Class I (C0G/NPO): Cap≥30pF, D.F≤0.1%; Cap<30pF, D.F≤1/(400+20C) Class II (X7R): ≤2.5%												
4.	Temperature Coefficient	IEC 60384-21/22 4.6	With no electrical load. <table border="1" style="margin-left: auto; margin-right: auto;"> <thead> <tr> <th>T.C.</th> <th>Operating Temp</th> </tr> </thead> <tbody> <tr> <td>C0G(NPO)</td> <td>-55~125°C at 25°C</td> </tr> <tr> <td>X7R</td> <td>-55~125°C at 25°C</td> </tr> </tbody> </table>	T.C.	Operating Temp	C0G(NPO)	-55~125°C at 25°C	X7R	-55~125°C at 25°C	<table border="1" style="margin-left: auto; margin-right: auto;"> <thead> <tr> <th>T.C.</th> <th>Capacitance C ange</th> </tr> </thead> <tbody> <tr> <td>C0G(NPO)</td> <td>Within ±30ppm/°C</td> </tr> <tr> <td>X7R</td> <td>Within ±15%</td> </tr> </tbody> </table>	T.C.	Capacitance C ange	C0G(NPO)	Within ±30ppm/°C	X7R	Within ±15%
T.C.	Operating Temp															
C0G(NPO)	-55~125°C at 25°C															
X7R	-55~125°C at 25°C															
T.C.	Capacitance C ange															
C0G(NPO)	Within ±30ppm/°C															
X7R	Within ±15%															
5.	Insulation Resistance	IEC 60384-21/22 4.5.3	* To apply voltage at 500VDC for 60 sec. * The charge current shall not exceed 0.05A.	Class I (NP0): ≥ 100GΩ or RxC ≥ 1000 Ω-F whichever is smaller. Class II (X7R): ≥ 10GΩ or RxC ≥ 500 Ω-F whichever is smaller.												
6.	Voltage proof (Dielectric Strength)	IEC 60384-14 4.2.1	* To apply voltage: X Capacitor: 1075Vdc (4.3U _R) Y Capacitor: 1500Vac * Duration: 60 sec. * The charge current shall not exceed 0.05A.	* No evidence of damage or flashover during test. * The voltage shall be raised from the near zero to the test voltage a rate not exceeding 150V(r.m.s.)/sec.												
7.	Solderability	IEC 60384-21/22 4.10	* Solder temperature: 245±5°C * Dipping time: 2±0.2 sec.	75% min. coverage of all metalized area.												
8.	Resistance to Soldering Heat	IEC 60384-14 4.4 IEC 60384-21/22 4.9	* Solder temperature: 260±5°C * Dipping time: 10±1 sec * Preheating: 120 to 150°C for 1 minute before immerse the capacitor in a eutectic solder. * Before initial measurement (Class II only): Perform 150+0/-10°C for 1 hr and then set for 48±4 hrs at room temp. * Measurement to be made after keeping at room temp. for 24±2 hrs (Class I) and 48±4 hrs (Class II)	* No visible damage. * Cap change: NP0: within ±2.5% or ±0.25pF whichever is larger. I.R: More than 1GΩ X7R: within ±10% I.R: More than 1GΩ												
9.	Humidity (Damp Heat) Steady State	IEC 60384-14 4.12	* Test temp.: 40±2°C * Humidity: 90~95% RH * Test time: 500+24/-0hrs. * Applied Voltage:250Vac * Measurement to be made after keeping at room temp. for 24±2 hrs (Class I) and 48±4 hrs (Class II)	* No remarkable damage. * Cap change: NP0 within ±5% or ±0.5pF whichever is larger X7R within ±15% * D.F Value: NP0 ≤ 0.25% X7R: ≤5.0% * I.R. ≥1GΩ * Dielectric strength satisfies the specified initial value												

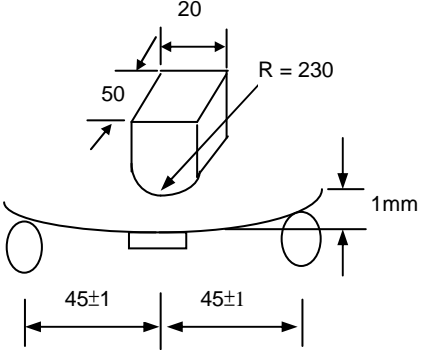
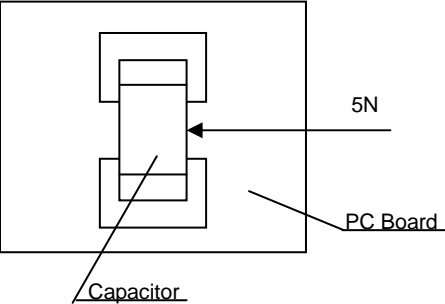
No.	Item	Standard Method	Test Condition	Requirements
10.	Endurance	IEC 60384-14 4.14	<p>* Impulse Voltage: Each individual capacitor shall be subjected to a $V_p = 5.0\text{KV}$ (X1Y2 Class Impulse 5KV) & $V_p = 6.0\text{KV}$ (X1Y2 Class Impulse 6KV) impulse for three times before applied to endurance test. Additional pulse test 10/700μs before endurance test for Y3 class (IEC60950) *Test Temp.: 125\pm3$^{\circ}\text{C}$ * Test time:: 1000+48/-0 hrs. * Applied Voltage: X capacitor: 1.25U_R (312.5Vac) Y capacitor: 1.70U_R (425Vac) Once every hour the voltage shall be increased to 1000Vrms for 0.1 sec. * Measurement to be made after keeping at room temp. for 24\pm2 hrs (Class I) and 48\pm4 hrs (Class II)</p>	<p>* Appearance : No mechanical damage. * Cap change: NP0 within $\pm 5\%$ or $\pm 0.5\text{pF}$ whichever is larger. X7R within $\pm 20\%$ * D.F Value: NP0 $\leq 0.25\%$ X7R: $\leq 5.0\%$ * I.R. $\geq 1\text{G}\Omega$ * Dielectric strength satisfies the specified initial value</p>
11.	Resistance to Flexure of Substrate	IEC 60384-21/22 4.8	<p>* Capacitors mounted on a substrate. The board shall be bent 1mm with a rate of 1mm/sec.</p> 	<p>* No remarkable damage. * Cap change is less than 10%. (This capacitance change means the change of capacitance under specified flexure of substrate from the capacitance measured before the test.)</p>
12.	Robustness of terminations (Adhesive Strength of Termination)	IEC 60384-21/22 4.15 IEC 60384-1 4.13	<p>* Capacitors mounted on a substrate. A force of 5N applied perpendicular to the place of substrate and parallel the line joining the center of terminations for 10\pm1 sec.</p> 	<p>* No remarkable damage or removal of the terminations.</p>
13.	Passive Flammability	IEC 60384-14 4.17 IEC 60384-1 4.38	<p>* Volume sample: 21.56 mm³ * Flame exposure time: 5 sec Max. * Category of flammability : C.</p>	<p>* Capacitor didn't burn at all</p>
14.	Active Flammability	IEC 60384-21/22 4.18	<p>* The capacitors applied U_R (250Vac). Then each sample shall be subjected to 20 discharges from a tank capacitor, charge to a voltage that, when discharged, place U_i 2500V for X2Y3, U_i 5000V for X1Y2 across the capacitor under test. The interval between successive discharges shall be 5 sec.</p>	<p>* The cheese cloth shall not burn with a flame.</p>
15.	Impulse Voltage	IEC 60384-14 4.13	<p>* X1 : 4.0KV, X2 : 2.5KV. * Y2 : 5.0KV, Y3 : None. * Number of impulse : 24 max.</p>	<p>* There shall be no permanent breakdown or flashover.</p>